

APPLICATION BULLETIN



APPLICATION: Bulk Screw Feeder

INDUSTRY: Packaging

PRODUCT: Multi-Speed Drive (MSDr)

BULK SCREW FEEDER

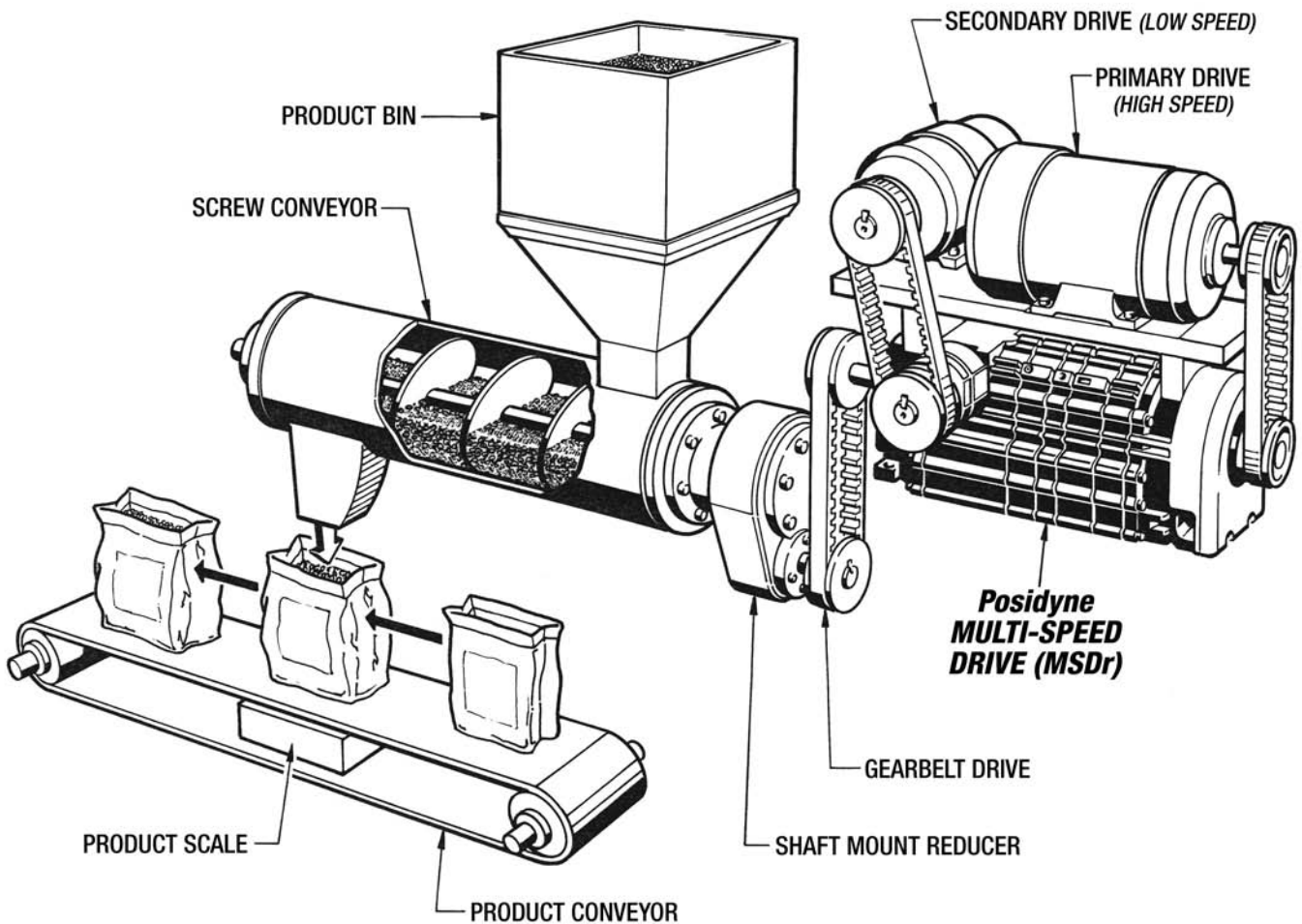

BULK SCREW FEEDER

WHERE THEY ARE USED: The bulk feeder can be found in many places where bags and boxes are filled with bulk materials including cereal, dog food, cat food, animal feeds, bird seed, concrete, fertilizer, charcoal etc.

HOW THEY WORK: The **Multi-Speed Drive (MSDr)** is used to power a feeder screw conveyor. To fill the bag quickly the screw is operated at a high speed to near the full level of the bag or box, at which point the Multi-Speed Drive is shifted to a low speed (10:1 or more) to fill to the exact level. When full the screw is stopped, a new bag introduced and the cycle begins again.

PROBLEMS SOLVED: The Dual Clutch **Multi-Speed Drive (MSDr)** can quickly shift from high speed to low speed to stop either from a preset program, manually, or from variable automatic inputs in a precise and repeatable way. By removing the motors from the starting and stopping process the high surges in current to the motors and back to the line are eliminated. The shift points and stopping position can be readily changed to meet changing product or container size.

IMPORTANT FEATURES:

- Dual clutches with integral reduction for a compact shiftable drive.
- Multiple surface **Oil Shear** design clutch and brake stack for precise repeatable operation and long life.
- Continuously running motors reduce surges, which can be expensive and detrimental to motors and controls.
- Simple control of actuation air to change the shift point and stopping or starting position.

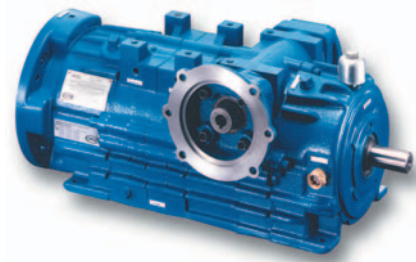

FORCE CONTROL INDUSTRIES, INC.

3660 Dixie Highway Fairfield, Ohio 45014

Phone: 513-868-0900 Fax: 513-868-2105

E-Mail: info@forcecontrol.com Web: www.forcecontrol.com