

APPLICATION BULLETIN



APPLICATION: Stone Cutting Equipment

INDUSTRY: Stone Cutting and Facing

PRODUCT: High Speed Reversing Drive (HSRvD) Type II

STONE CUTTING EQUIPMENT

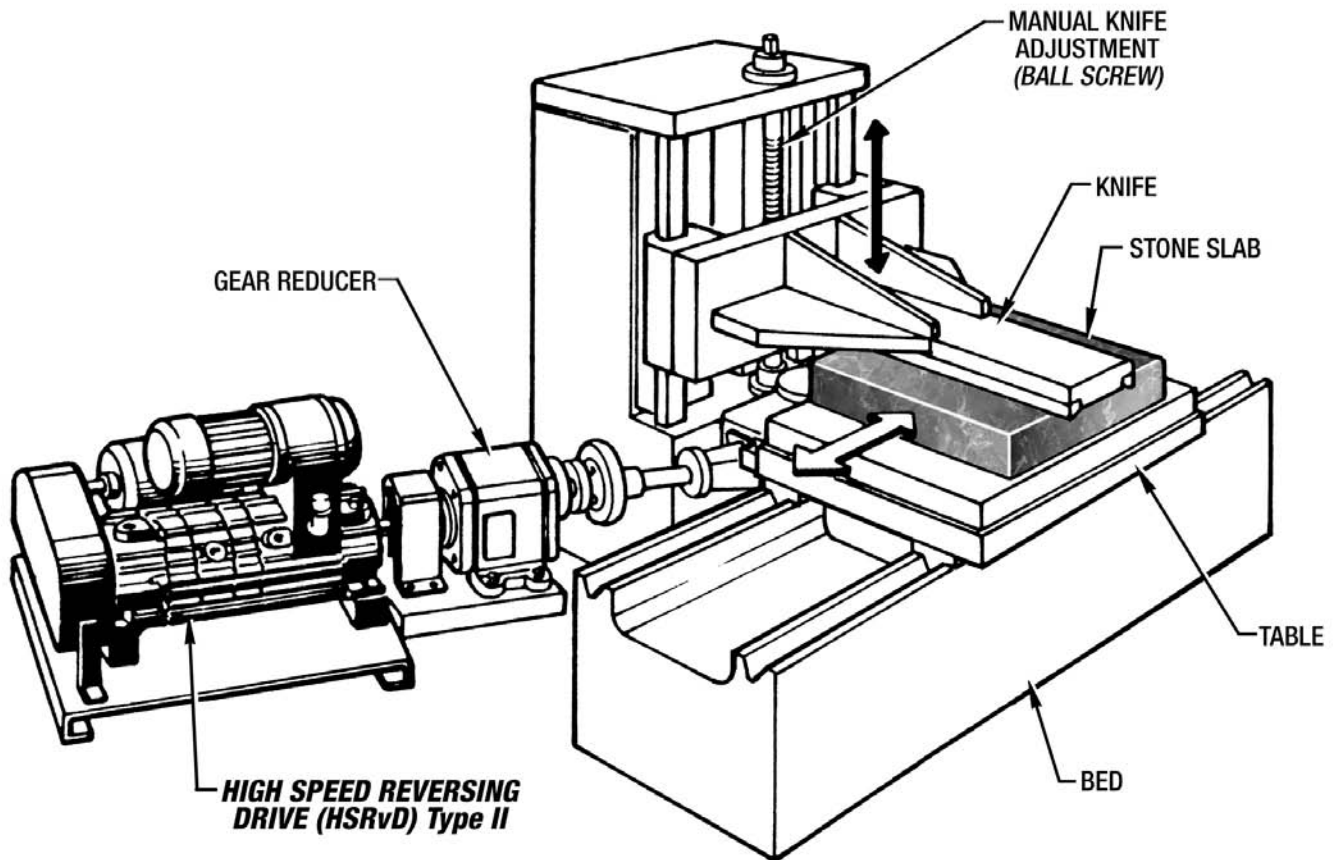

STONE CUTTING EQUIPMENT

WHERE THEY ARE USED: Many stone cutting plants use a reciprocating table to cut stone either to a specific dimension or to “clean up” a surface of a stone.

HOW THEY WORK: An operator adjusts the position of the blade manually. The stone is indexed forward beneath the blade and is cut to desired specs. When the stone bed is full forward a mechanical limit switch is actuated and the table returns.

PROBLEMS SOLVED: The stone bed originally indexed forward by a 30 HP 1800 RPM motor and a dry friction clutch. Constant maintenance and downtime on this clutch created a loss of production as well as late deliveries to customers.

IMPORTANT FEATURES:

- Clutches reversed allowing the motors to run continuously.
- Clutch brake is totally enclosed allowing for long life in a hostile environment.
- Air set brake and clutch provided a soft acceleration and de-acceleration.
- Shock load to table and drive system have been greatly reduced due the oil in the reversing drive.
- Oil cools and lubricates the friction discs to provide long life.



FORCE CONTROL INDUSTRIES, INC.

3660 Dixie Highway Fairfield, Ohio 45014

Phone: 513-868-0900 Fax: 513-868-2105

E-Mail: info@forcecontrol.com Web: www.forcecontrol.com